



PR70

Meter, Mix and Dispense System with Graco® Control Architecture



Distributed by



**Sealant Equipment
& Engineering, Inc.**

Manufacturers of Precision Dispense Systems & Valves

45677 Helm St. Plymouth, MI 48170
Email: Sales@SealantEquipment.com

SealantEquipment.com/Graco

(734) 459-8600

Advanced Graco Distributor and Design Center for Adhesive and Sealant Equipment

PROVEN QUALITY. LEADING TECHNOLOGY.

PR70 – Technology You Can Count On

Graco reliability. Industry-proven accuracy. Intuitive design.

The PR70 fixed ratio system accurately meters, mixes and dispenses two-component medium- to low-viscosity materials for potting, gasketing, sealing, encapsulation and syringe filling. All the features you need in a compact, modular design.

Multiple Feed Systems

A variety of feed package options are available:

- Polyethylene tanks
- Stainless steel tanks
- Off-board tanks for high-volume applications and reduced material refills
- Accumulators for high-viscosity materials

MD2 Valve

High-pressure accuracy with multiple seat styles and adjustable snuffback for clean, precise dispensing

Compact Benchtop Unit

- Stable, strong machine base for secure installation
- Small footprint saves valuable space

Intuitive User Interface

Digital shot size entry, machine monitoring and feedback for total control

PR70

Two-component dispensing at an affordable price



Fluid Control Module

- Offers a simplified wiring system and board-level diagnostics
- Modular approach is easier to operate, easier to maintain

Proven Ratio Accuracy

Multiple tube sizes to pinpoint specific target ratios and deliver ratio accuracy to $\pm 1\%$



Long-Life Design

Optimized pump support, seal design, and Chromex™ rods provide twice the life of existing systems

Variable for a Variety of Applications

The PR70v. Developed for variable ratio dispensing.

The PR70v is a variable ratio meter, mix and dispense system for processing a wide range of two-component material formulations.

- Exceptional performance with material ratios from 1:1 to 24:1
- Proven ratio accuracy to $\pm 1\%$
- Versatile – ideal for applications using up to 70 cc shot sizes
- Improved pump design increases seal life with less maintenance
- Multiple levels of user interface to best support your application



Variable Ratio Drive

Change materials, dial in specific ratio or simply hit a very wide ratio

Optional Accumulators

Allow you to handle higher viscosity material

Advanced Display Module

Upgrade to advanced control for expanded features including:

- Recirculation
- Programmable dispensing – including seven unique sequences and up to 50 shot sizes
- Multiple shot counters
 - Numeric keypad for easy data entry

Multiple Dispense Valve Option

Choose from mast-mounted or hand-operated to best fit your application

PR70v

Variable-ratio two-component dispensing

Compact Benchtop Unit

- Stable, strong machine base for secure installation
- Small footprint saves valuable space

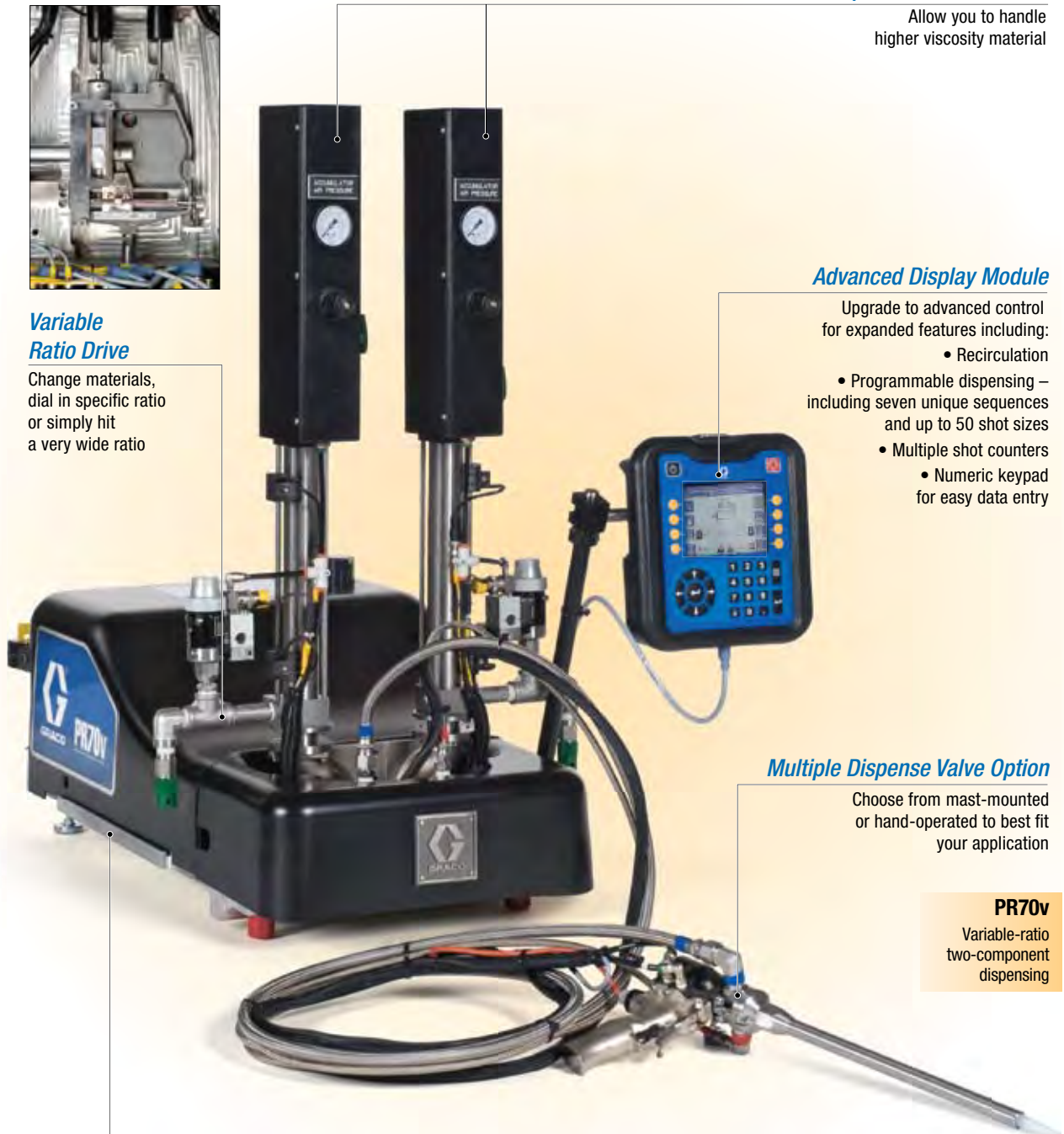

Performance You Can Trust



Reliability and durability to maximize system performance

- Cast pump bodies for improved seal alignment
- Chromex shafts and Severe Duty™ cylinders combined with stainless steel fittings provide long pump life with no corrosion
- Shaft seals designed for extended life and easy replacement
- Preventive maintenance counter to plan system rebuilds around your production schedule
- Linear thrust bearings eliminate side loading to maximize seal life and performance

Quick system training and lower meantime to repairs

- Standard electronic controls allow for digital shot entry in grams
- Built-in, easy to set up purge timer keeps system up and production running
- Graco Control Architecture modules, with built-in diagnostics, allow for quick troubleshooting
- Modular design eliminates point-to-point wiring – a quick board change-out gets your system up and running

Performance and accuracy to handle the toughest materials

- Stainless steel design reduces the chance of a material incompatibility
- Positive displacement pumps deliver ratio accuracy to $\pm 1\%$
- Linear transducer monitors piston velocity to provide ratio assurance and reduce scrap and re-work
- Shot size ranges from 2 to 70 cc's
- Ratio range from 1:1 to 24:1 with variable drive

PR70 Key Industries and Applications

- Automotive electronics
- Consumer electronics
- Medical
- Sporting goods
- Automotive components
- Appliance
- Product assembly and more

Easy-to-Use Interface



Graco Control Architecture

PR70 and PR70v Dispense Systems feature intuitive user interfaces based on the Graco Control Architecture, a modular system of processing and control components. Products using the Graco Control Architecture provide similar interface functionality across your plant and simplify training. Maintenance and service is easier too, thanks to built-in troubleshooting tools and simple, modular part replacement.

Advanced Display Module

When you upgrade to the Advanced Display Module, you gain extra capabilities that allow you to accomplish more in your production area. The Advanced Display Module enables expanded features including:

- Recirculation capability
- Programmable shot sizes and sequencing – up to 50 different shot sizes and seven sequences
- Integrated heater control
- Large, bright color screen makes the system easier to see and use
- Key pad entry makes it easy to program and reduces operator training time



Recirc Mode option prevents materials from setting overnight



Set-up screen gives users easy access heat options

Display Module

- Simple system electronic controls with diagnostics and job data reporting
- LCD graphical interface saves time by enabling accurate shot size programming
- Automatic alarms notify you when pumps need attention
- Schedule preventive maintenance at your convenience for less downtime

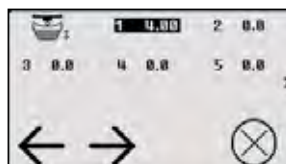

Shot size entry screen – enter up to five different shot sizes

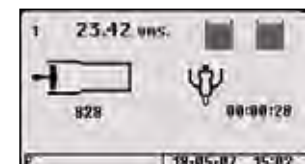

Operation screen displays current shot, material availability and pump ready indicators

Feed Systems

A range of feed package options available for agitation, heat and degassing applications

Standard tank sizes simplify your system options.

Choose from:

- 3.0 and 7.5 liter stainless steel direct-mount tanks
- 8 liter direct-mount polyethylene (PE) tanks
- 7.5 and 15 gallon stainless steel off-board tanks
- Material conditioning options – multiple covers available for agitation, degassing or desiccant packs. Dust covers also available.



Off-board tanks for high volume applications and reduced material refills



Stainless Steel (SST) Tanks



Polyethylene (PE) Tanks



Advanced Options Customize Dispensing Systems

Reduce your cost of ownership without compromising your process

Choose any of these advanced options to customize your system using Graco standard parts.

Ratio Assurance Packages

Make sure your system stays within operating parameters by choosing Graco's optimum ratio assurance package. To help you reduce material waste, Graco offers two different packages:

- Pressure transducers monitor the outbound pressure of the metering tubes and sound an alarm if dispense profile changes
- Flow meters monitor the flow of each component to ensure ratio accuracy

Recirculation Option

Graco's new optional recirculation option, in conjunction with the advanced display module, enables manual recirculation to keep your material performing to your specifications.



- Keeps particles suspended in the material
- Prevents particulates from settling in tank or hose lines
- Virtually eliminates pack-out
- Saves maintenance time

Low-Power Temperature Control Module

With Graco's advanced display module and low-power temperature control module, you can control system heat through the user interface.

- Easy to set up and use
- Allows you to set up parameters to ensure material is at temperature before dispensing
- Choose from two- or four-zone boxes



*Low-Power
Temperature
Control Module*

Input/Output Options

Using the Graco Control Architecture, the PR70 allows a range of remote operating options including:

Display Module

- Remotely activate the dispense valve in either an on/off mode or a single shot dispense model

Advanced Display Module

- Four-bit digital I/O allows you to select up to 15 different shot sequences to dispense in shot mode
- Three-bit digital I/O allows you to select seven, 10-step, shot sequences if your part requires more than one shot

Auto Refill Package

- Refill your system automatically with two Graco transfer pumps
- Saves time and labor expenses
- Optimizes system uptime



Auto Refill Package

MD2: Part of a Complete System

Micro Dispensing — We've Got You Covered!

- Handles a range of materials
- Minimizes maintenance time and costs while maximizing dispense time
- Designed with fewer parts and is easy to clean
- Streamlines maintenance and service
- Complete modular design adapts to different installation needs
- No unique tools required

Independent Air Cylinder

Improves mean time to repair (MTTR)

All SST Wetted Section

Maximizes material compatibility

Two Nose Options

Customizes material mixing

Grease Isolation Chamber

- Ideal for moisture-sensitive materials
- Accessible grease fittings for easy maintenance

Adjustable Inlet Position

- Flexibility during system installation
- Minimizes dead spaces in fluid path

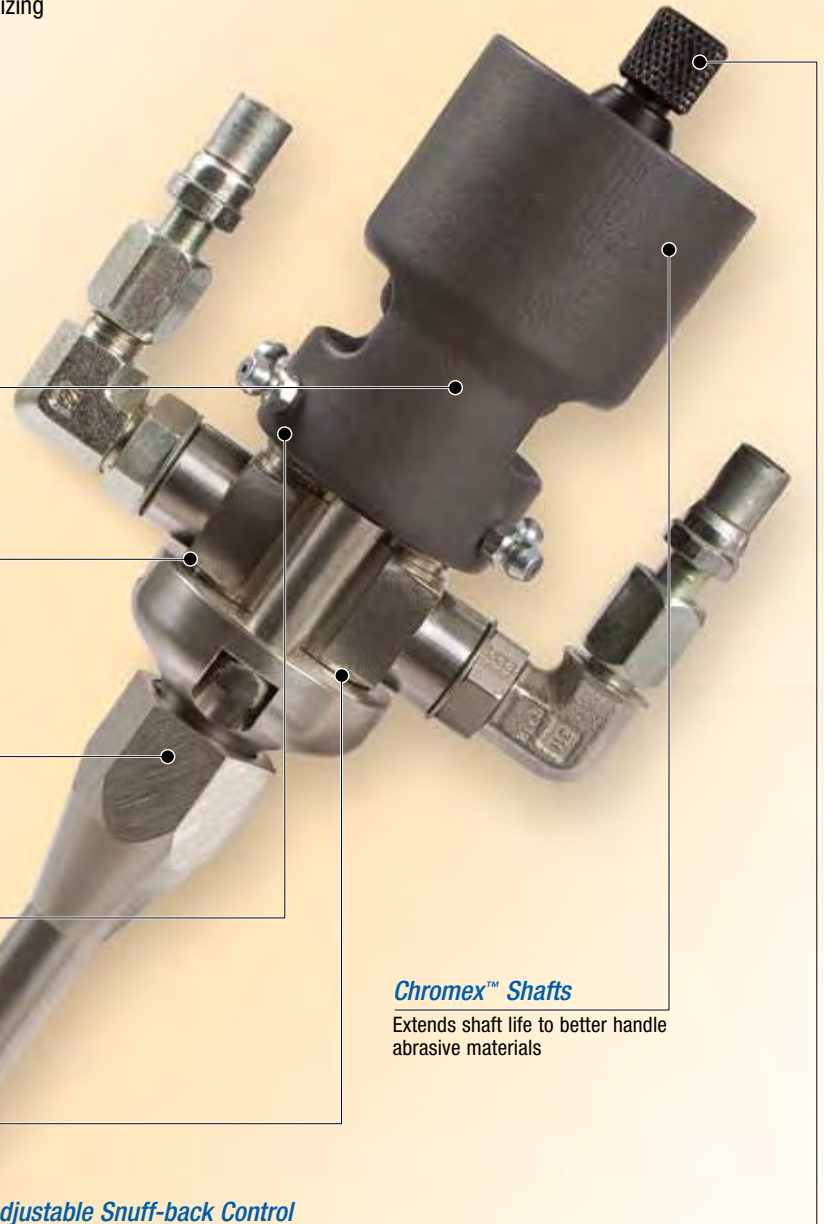

Chromex™ Shafts

Extends shaft life to better handle abrasive materials

Adjustable Snuff-back Control

Dispenses material only where you need it

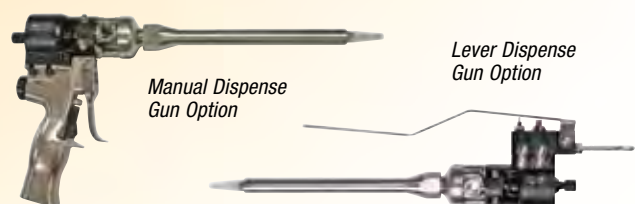

PR70 Configurator

Building the Perfect PR70 is Easy!

Customize the PR70 with the features you need. Contact your local Graco Distributor to see all the available configured options.

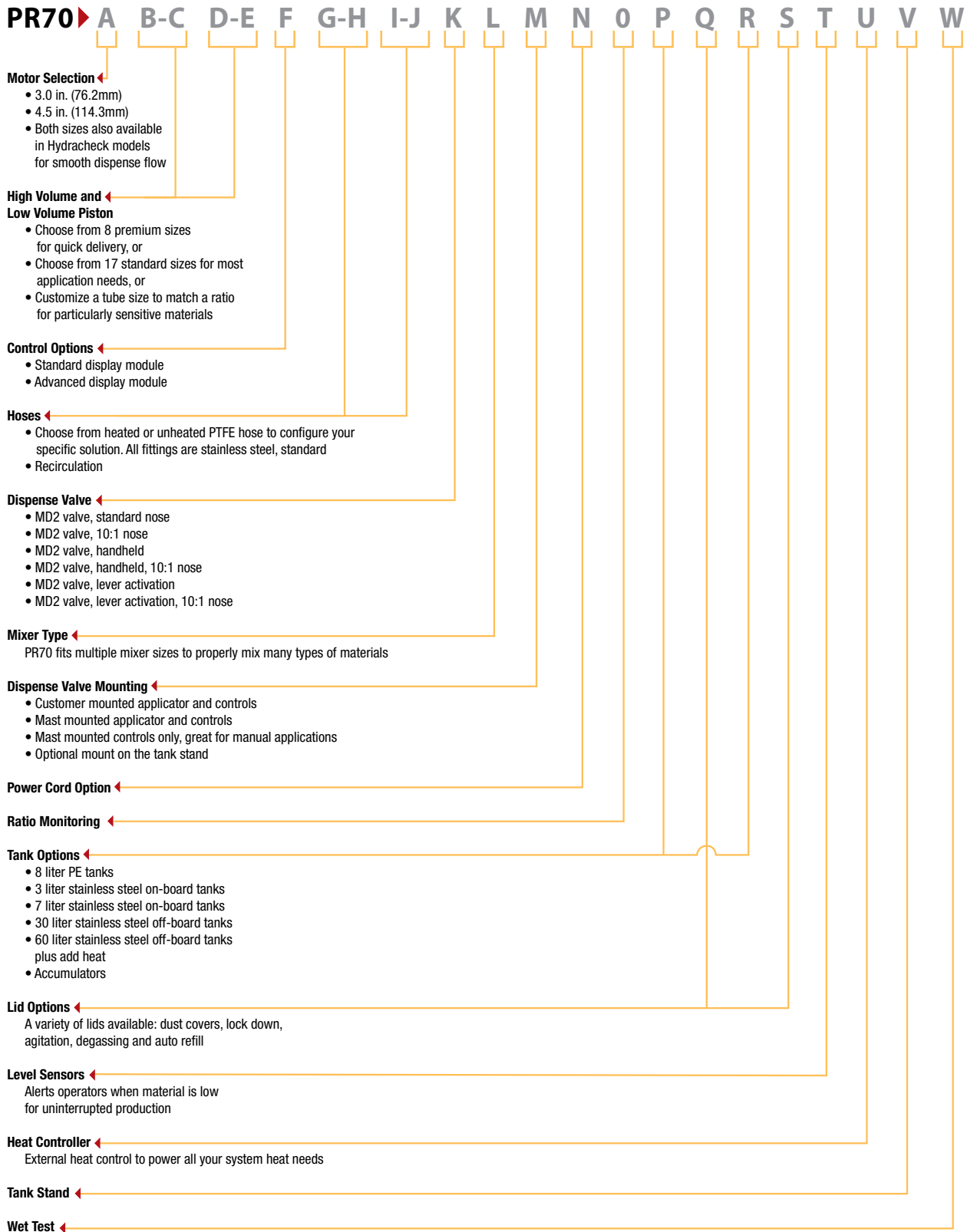

Technical Specifications

Metering Pump Effective Area	0.124 – 1.49 in ² (80 – 960 mm ²) per side
Small Air Cylinder Effective Area	7.07 in ² (4560 mm ²)
Large Air Cylinder Effective Area	15.9 in ² (10260 mm ²)
Maximum Stroke Length	1.50 in (38.1 mm)
Minimum Stroke Length	0.23 in (5.8 mm)
Volume per Cycle	0.12 – 4.3 in ³ (2 – 70 cc)
Pump Cycles per 1L (.26 gal)	500 – 14.3
Ratios (fixed)	1:1 to 12:1 depending on cylinders selected
Ratios (variable)	1:1 to 24:1 depending on cylinders selected
Maximum Fluid Working Pressure	3000 psi (207 bar, 20.7 MPa)
Maximum Air Input Pressure	100 psi (7 bar, 0.7 MPa)
Maximum Cycle Rate	30 cpm
Maximum Operating Temperature	70° C (160° F) nylon pistons 50° C (120° F) UHMWPE pistons or PE tanks
Air Inlet Size	1/4 NPT(f)
Pump Fluid Outlet Size	-03, -04, -06, -08 or -12 JIC fittings for 3/16 in (4.8 mm), 1/4 in (6.4 mm), 3/8 in (9.5 mm), 1/2 in (12.7 mm), 3/4 in (19.1 mm) hoses
Wetted Parts	303/304, 17-4 PH, hard chrome, Chromex™, carbide, chemical resistant O-rings, PTFE, nylon, UHMWPE
Weight – PR70	120 lb (55 kg) typical with two 7.5 l tanks 330 lb (150 kg) typical with two 60 l tanks
Weight – PR70v	160 lb (73 kg) typical with two 7.5 l tanks 370 lb (168 kg) typical with two 60 l tanks
Compressed Air	< 10 scfm typical (varies with cycle time)
Electrical Power	100-240V 50/60Hz 1 phase for machine – 80 watts 208-240V 50/60Hz 1 phase for heat – 10 kW max 120 or 240V 50/60Hz 1 phase for on-board agitators
Instruction Manuals	
PR70 with Display Module Operation & Maintenance	312393
PR70/PR70v with Advanced Display Module	312759
MD2 Valve Instructions and Parts	312185
PR70/PR70v Repair and Parts	312760
PR70/PR70v Feed System	312394
PR70v Integrated Heat	312761

PR70 machines and complete configured packages carry the CE mark.

PR70 Accessories

PART NO.	DESCRIPTION	PART NO.	DESCRIPTION
LC0097	Desiccant Dryer, 3/8 in NPT with adapter and cartridge	LC0084	Mixer, 3/16 (4.8 mm) x 32, 250 mixers
LC0098	Desiccant Dryer Refill Cartridge	LC0085	Mixer, 1/4 (6.5 mm) x 24, 250 mixers
LC0095	Nitrogen Kit for 30 L and 60L tank, 1 tank	LC0086	Mixer, 3/8 (9.8 mm) x 24, 250 mixers
LC0096	Nitrogen Kit for 30 L and 60L tank, 2 tanks	LC0087	Mixer, 3/8 (9.8 mm) x 36, 250 mixers
LC0008	Cord, I/O interface with footswitch port	LC0088	Mixer, 3/8 (9.8 mm) Combo, 250 mixers
LC0099	Vacuum Transfer Pump, 120V, down to 25 Torr	LC0090	Mixer, 3/16 (4.8 mm) x 32 Luer Lock, 250 mixers
LC0100	Vacuum Transfer Pump, 240V, down to 25 Torr	LC0089	Mixer, 1/4 (6.5 mm) x 24 Luer Lock, 250 mixers
256205	Vacuum Kit for single on-board tank	LC0091	3.0 in Air Cylinder Rebuild Kit
256206	Vacuum Kit for dual on-board tank	LC0092	4.5 in Air Cylinder Rebuild Kit
256207	Vacuum Kit for single off-board tank	LC0093	Check Valve Rebuild Kit
256208	Vacuum Kit for dual off-board tank	LC0094	Rear Pump Seal Rebuild Kit
256179	Auto-refill, tank mount valve (1), solenoid and mounting bracket	LCC-XXX	Replacement Cylinder (xxx is the area of the Cylinder, ex. LCC960)
256659	Auto-refill, 1/4 in solenoid for feed package air shutoff	LCF-XXX	Nylon Piston Rebuild Kit (xxx is the area of the Cylinder, ex. LCF960)
256660	Auto-refill, 1/2 in solenoid for feed package air shutoff	LCE-XXX	UHMWPE Piston Rebuild Kit (xxx is the area of the Cylinder, ex. LCF960)
255220	MD2, Convert Soft Seat nose to hard seat (Hard Seat rebuild), needle and nose	LC1-XXX	Special Nylon Metering Assemblies: where xxx is the whole number area (in mm ²). Note: Custom tubes are available only in whole mm ² increments
255219	MD2, Soft Seat rebuild, needle and nose	LC2-XXX	Special UHMWPE Metering Assemblies: xxx is the whole number area (in mm ²). Note: Custom tubes are available only in whole mm ² increments and xxx > 160 mm ²
255218	MD2, kit rebuild, back end of wet section (no needle or seat)	LCD-XXX	Replacement Special Cylinder (xxx is the area of the Cylinder, ex. LCD333)
255217	MD2, Kit rebuild, air cylinder	LCF-XXX	Special Nylon Piston Rebuild Kit (xxx is the area of the Cylinder, ex. LCF333)
LC0063	Mixer, 3/16 (4.8 mm) x 32, 10 mixers with shroud	LCE-XXX	Special UHMWPE Piston Rebuild Kit (xxx is the area of the Cylinder, ex. LCF333)
LC0057	Mixer, 1/4 (6.5 mm) x 24, 10 mixers with shroud		
LC0058	Mixer, 3/8 (9.8 mm) x 24, 10 mixers with shroud		
LC0059	Mixer, 3/8 (9.8 mm) x 36, 10 mixers with shroud		
LC0060	Mixer, 3/8 (9.8 mm) Combo, 10 mixers with shroud		
LC0061	Mixer, 3/16 (4.8 mm) x 32 Luer Lock, 10 mixers with shroud		
LC0062	Mixer, 1/4 (6.5 mm) x 24 Luer Lock, 10 mixers with shroud		
LC0077	Mixer, 3/16 (4.8 mm) x 32, 50 mixers		
LC0078	Mixer, 1/4 (6.5 mm) x 24, 50 mixers		
LC0079	Mixer, 3/8 (9.8 mm) x 24, 50 mixers		
LC0080	Mixer, 3/8 (9.8 mm) x 36, 50 mixers		
LC0081	Mixer, 3/8 (9.8 mm) Combo, 50 mixers		
LC0082	Mixer, 3/16 (4.8 mm) x 32 Luer Lock, 50 mixers		
LC0083	Mixer, 1/4 (6.5 mm) x 24 Luer Lock, 50 mixers		

Special Metering Sizes
(Not factory installed)

Standard and Super Standard



ABOUT GRACO

PROVEN QUALITY. LEADING TECHNOLOGY.

Founded in 1926, Graco is a world leader in fluid handling systems and components. Graco products move, measure, control, dispense and apply a wide range of fluids and viscous materials used in vehicle lubrication, commercial and industrial settings.

The company's success is based on its unwavering commitment to technical excellence, world-class manufacturing and unparalleled customer service. Working closely with qualified distributors, Graco offers systems, products and technology that set the quality standard in a wide range of fluid handling solutions. Graco provides equipment for spray finishing, protective coating, paint circulation, lubrication, and dispensing sealants and adhesives, along with power application equipment for the contractor industry. Graco's ongoing investment in fluid management and control will continue to provide innovative solutions to a diverse global market.

GRACO LOCATIONS

MAILING ADDRESS

P.O. Box 1441
Minneapolis, MN 55440-1441
Tel: 612.623.6000
Fax: 612.623.6777

AMERICAS

MINNESOTA

Worldwide Headquarters
Graco Inc.
88 -11th Avenue N.E.
Minneapolis, MN 55413

EUROPE

BELGIUM

European Headquarters
Graco N.V.
Industrieterrein-Oude Bunders
Slakweidestraat 31
3630 Maasmechelen,
Belgium
Tel: 32.89.770.700
Fax: 32.89.770.777

ASIA PACIFIC

AUSTRALIA

Graco Australia Pty Ltd
P.O. Box 558
Level 2 / 541 Blackburn Rd.
Mount Waverley VIC 3149
Australia
Tel: 61.3.9550.0848
Fax: 61.3.9550.0816

CHINA

Graco Hong Kong Ltd.
Shanghai Representative Office
Room 118 1st Floor
No.2 Xin Yuan Building
No.509 Cao Bao Road
Shanghai, P.R. China 200233
Tel: 86.21.649.50088
Fax: 86.21.649.50077

INDIA

Graco Hong Kong Ltd.
India Liaison Office
Room 103, Level 4, Augusta Point
Golf Course Road
Gurgaon, Haryana, India 122001
Tel: +91.124.435.4208
Fax: +91.124.435.4001

JAPAN

Graco K.K.
1-27-12 Hayabuchi
Tsuzuki-ku
Yokohama City, Japan 2240025
Tel: 81.45.593.7300
Fax: 81.45.593.7301

KOREA

Graco Korea Inc.
Choheung Bank Building
4th Floor #1599
Gwanyang-Dong, Dongan-Ku,
Anyang-Si, Gyunggi-Do,
Korea 431-060
Tel: 82(Korea).31.476.9400
Fax: 82(Korea).31.476.9801

SALES/ DISTRIBUTION/ SERVICE

Call today for product information

Distributed by



**Sealant Equipment
& Engineering, Inc.**

Manufacturers of Precision Dispense Systems & Valves

45677 Helm St. Plymouth, MI 48170
Email: Sales@SealantEquipment.com

SealantEquipment.com/Graco
(734) 459-8600

Advanced Graco Distributor and Design Center for Adhesive and Sealant Equipment

Graco Ohio
330-966-3000
Fax 330-966-3006